



# SAFETY INFORMATION

## Two Drum Slitter Rewinder Safety

### INTRODUCTION

The purpose of the Slitter Rewinder is to slit and wind rolls of paper, paperboard and nonwovens of uniform tension and density across the width of the web. In converting plants, the Slitter Rewinder operation is intermittent and is always an off line operation.

Web product grades, properties, speeds and widths differ from plant to plant. The proper methods of threading and splicing therefore vary from Slitter Rewinder to Slitter Rewinder.

IT IS ESSENTIAL THAT OPERATING PERSONNEL BE THOROUGHLY TRAINED IN THE SLITTER REWINDER SAFETY AND THE OPERATING PROCEDURES APPLICABLE TO THE GRADE OF WEB PRODUCTS INVOLVED.

LACK OF PROPER TRAINING CAN BE A MAJOR CAUSE OF SERIOUS PERSONAL INJURY.

Slitter Rewinders are used to slit and rewind the rolls of coated or laminated paper, paperboard and nonwovens that were wound on a converting mill winder to make it ready for shipping to the end user. Slitter Rewinders run at very high speeds and adequate barrier guards and safety signs must be installed to protect and remind personnel of potential hazards. Refer to Figure 1 for typical converting Winder.

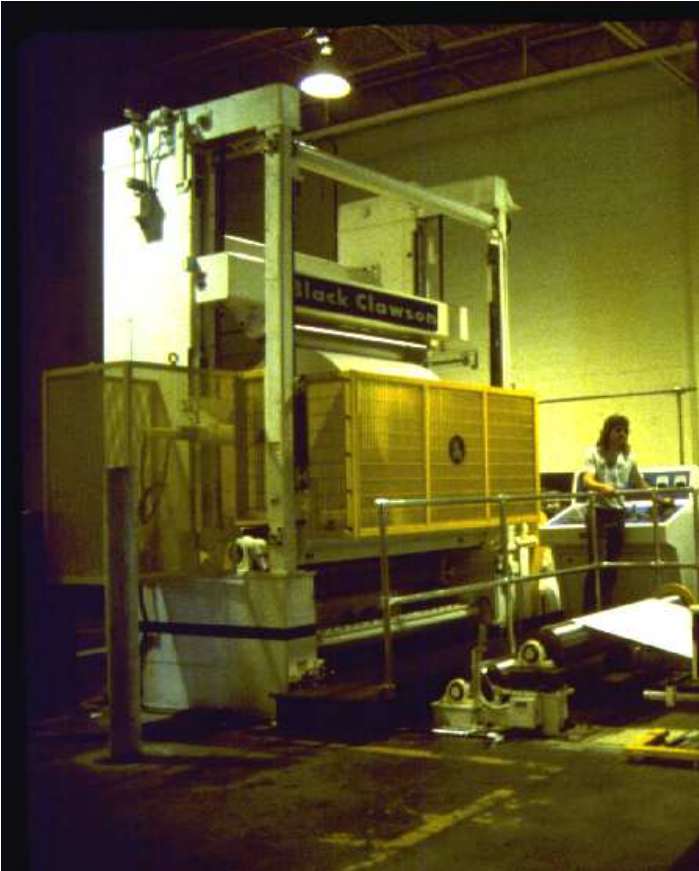

Figure 1



# SAFETY INFORMATION

## DANGER IN-RUNNING NIP

PERSONNEL MUST NEVER COME INTO CONTACT WITH THE IN-RUNNING NIP POINTS OF THE WINDING ROLL AND SLITTER REWINDER DRUMS OR THE WINDING ROLL AND THE RIDER ROLL. VERY SERIOUS PERSONAL INJURY CAN RESULT.

Refer to Figure 2 for nip points of winding roll.

The type of guarding needed to protect the operator from the in-running nip between the winding roll and Slitter Rewinder drum varies from Slitter Rewinder to Slitter Rewinder.

Although it is impossible to completely guard a Slitter Rewinder and still operate it, especially during the threading and splicing cycles, we present here in this bulletin a number of illustrations of barrier guards as well as instructions for safe threading and splicing.

This bulletin applies to converting Slitter Rewinders manufactured by Black Clawson Company, Black Clawson Converting Machinery LLC, Black Clawson Converting Machinery, Inc. and Davis-Standard, LLC. If the instructions in this bulletin do not apply to your particular Slitter Rewinder, please contact Davis-Standard, LLC. We can also assist you in developing a sheet threading system for your Black Clawson/Davis-Standard, LLC Slitter Rewinder or provide technical assistance to enable you to guard your Black Clawson/Davis-Standard, LLC Slitter Rewinder in accordance with OSHA Regulations.

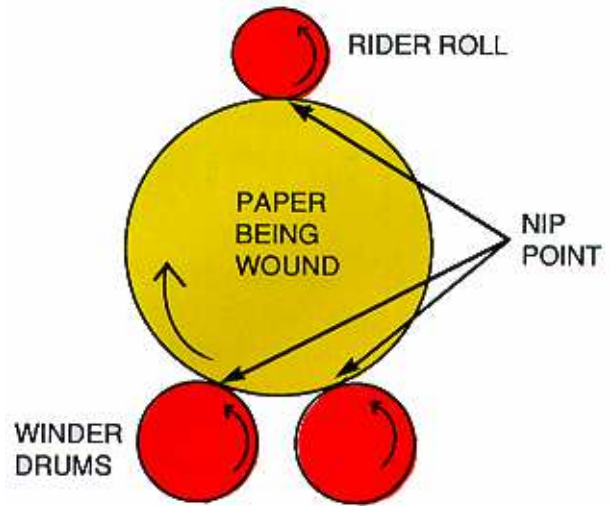

Figure 2

## REWINDER BARRIER GUARDS

OSHA requires that all Drum Slitter Rewinder nip points located on the operator's side be guarded by barrier guards of sufficient height to fully protect anyone working around them. The barrier guard must be interlocked with the drive mechanism to prevent operation above jog speed when the guard is not in place. The guard must also be interlocked so that the barrier guard cannot be raised or lowered from its operating position until the Slitter Rewinder has stopped.



# SAFETY INFORMATION

## REWINDER BARRIER GUARDS CONT.

The following illustrations show guards suitable for either shafted or shaftless winding.

Figure 3 shows a full width pivoted barrier guard that totally encloses the nipping points of the winding roll. The guard is raised by pneumatic cylinders interlocked with the main drive to prevent raising until the Slitter Rewinder has stopped. This is an excellent guard for retrofitting older Rewinders that do not comply with OSHA's requirements.



Figure 3

Some Slitter Rewinders require that the finished roll be removed by crane. A pivoted barrier guard would interfere with the crane hooks or sling.

Figure 4 shows a barrier guard intended for such a Slitter Rewinder operation designed in accordance with the requirements of OSHA.

Later versions of Black Clawson Converting Machinery, Inc./Davis-Standard, LLC state-of-the-art Slitter Rewinders have roll lowering cradles integrated into the frames. Examples of these are shown in Figures 5, 6, and 7.

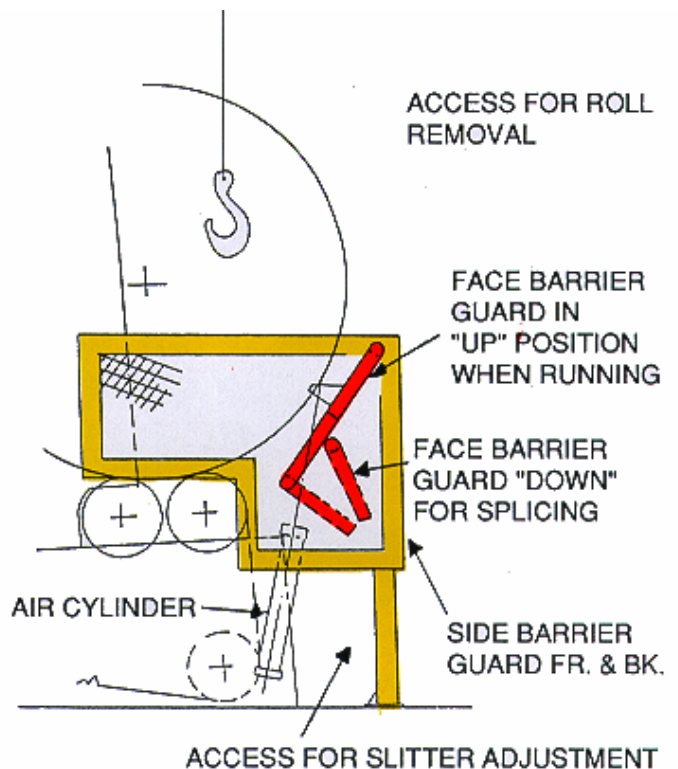

Figure 4



# SAFETY INFORMATION

## ROLL LOWERING CRADLE and SCOOP LOWERING TABLES

Slitter Rewinders equipped with roll lowering cradles as shown in Figures 5, 6, and 7 and scoop lowering tables as shown in Figure 8, must have only one push-button for lowering these devices. This push-button must be located so that the operator pressing the button has full view of the floor area occupied by the cradle or table in their lowered position. The push-button must be relocated if it does not meet with these recommendations.



Figure 5

It is recommended that roll lowering cradles and scoop tables be equipped with visible and audible alarms that are activated before and during the lowering cycle.

**SERIOUS PERSONAL INJURY COULD RESULT IF THE ROLL LOWERING PUSH-BUTTON IS ACTIVATED WHILE SOMEONE IS IN THE AREA.**

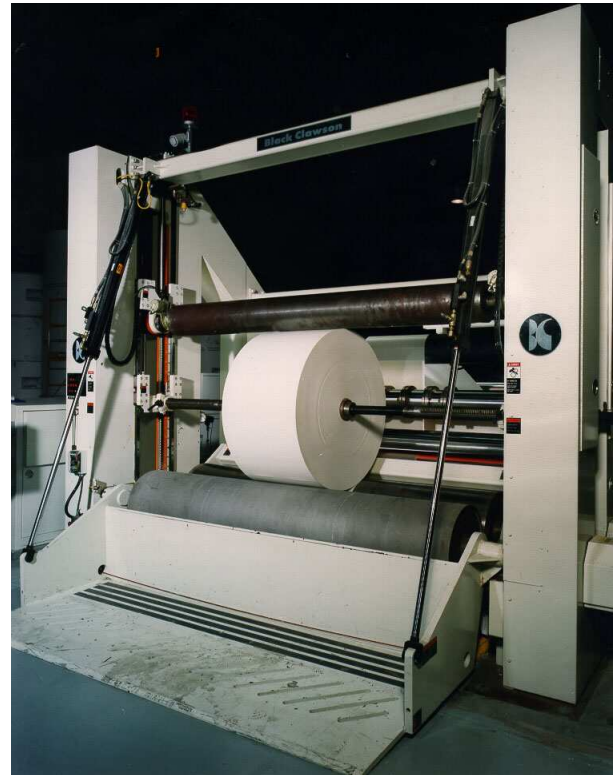

Figure 6

It is recommended that the edges of the cradle and the scoop lowering table and the floor area occupied by them in their lowered position be painted orange or with yellow and black stripes to warn of potential danger.

As the roll lowering cradle is also the barrier guard, the controls must also be interlocked with the drive in accordance with OSHA Regulations.

To prevent operators from standing too close to the side of the cradle or table, a rubber lip should be attached to the outside edges. The rubber lip will brush against operators standing too close, thereby alerting them to stand clear and not touch the lowering devices.



# SAFETY INFORMATION

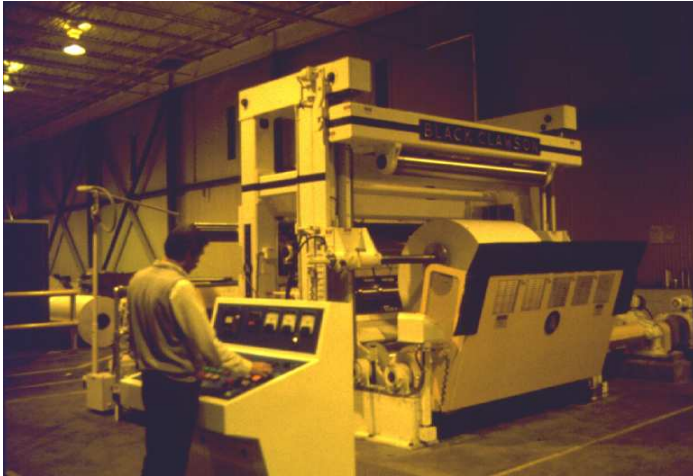

**Figure 7**

SERIOUS PERSONAL INJURY COULD RESULT BY GETTING TOES CAUGHT BETWEEN THE CRADLE OR TABLE AND FLOOR OR HAND BETWEEN THE CRADLE OR TABLE AND ROLL.

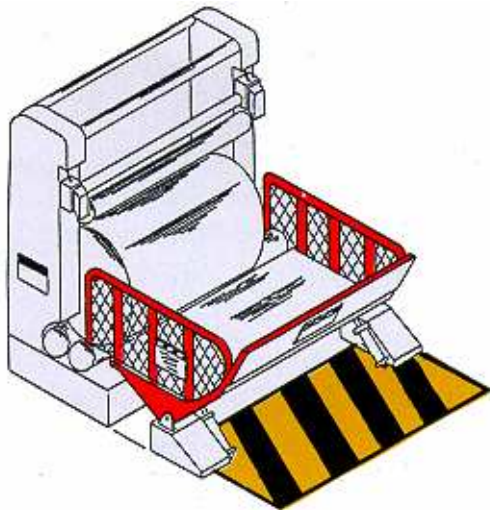

**Figure 8**

## WARNING THREADING

It is essential that operators be thoroughly trained in the threading of the Slitter Rewinder.

Although Slitter Rewinder operations are being automated, many are still labor intensive. In many cases, although threading devices are available, the operator must assist the threading device or thread by hand.

Threading is hazardous and can cause serious bodily injury unless the operator has been given and follows the proper training.

The Slitter Rewinder must be operated at slow speeds in either the thread or jog mode while guards are open. Guards which are open must be interlocked with the drive to prevent the Slitter Rewinder from running above the thread or jog speed.

AN OPERATOR MUST BE WITHIN REACH OF AN EMERGENCY STOP BUTTON AT ALL TIMES WHEN THE SLITTER REWINDER IS IN MOTION DURING THREADING.

Operators must read, understand and follow the plant's threading procedures applicable to its particular Slitter Rewinder. Although it is virtually impossible to describe the threading procedures for all Slitter Rewinders, the following are general rules for safe threading.

1. Ensure parent roll is properly located in the unwind stand and is free to rotate.
2. Retract all slitters.
3. Cut a tail at unwind.
4. At slow speed, thread tail through the web path to the slitter rewinder drums.

Note: ALWAYS USE JOG MODE WHEN THREADING BY HAND.



# SAFETY

# INFORMATION

## WARNING THREADING Continued

At the Slitter Rewinder drums, the web is either fed between the drums or over the front or rear drum. This will depend on grade of coated or laminated paper, paperboard or nonwoven being wound. Generally plant preference dictates winding mode.

**HAND THREADING IS TO BE AVOIDED IF POSSIBLE.**

Operators must be made aware of the hazard of nip points and thoroughly understand the plant's threading procedures.

**TO AVOID SERIOUS PERSONAL INJURY**, all hand threading at the drums must be done while the Slitter Rewinder is stopped. Threading between the drums or over the rear drum must be done at tending side. Threading over the front drum can be done at the center of the Slitter Rewinder.

One operator must thread the tail up to a second operator who, in full view of the operator at the control console, can either insert and jam the tail into the nip of the new core and the drum or attach the tail to the partly wound roll.

Before jogging always ensure there is sufficient slack between the Slitter Rewinder and the unwind stand to avoid tensions that could either tear the tail or pull the tail out of the nip.

All personnel must stand clear of the nip area before the tail is jogged at slow speed through the nip between the core/roll and drum.

Never hold onto or touch the tail while it is being jogged. Under no circumstances should the operator attempt to reinsert or reattach the tail while the drums are turning.

If the tail fails to go through the nip or comes loose, stop the Slitter Rewinder, reinsert or reattach the tail, stand clear, and jog the Slitter Rewinder to take the tail over the roll to the face side of the Slitter Rewinder.

The use of threading aids reduces threading time and can enhance the safety of Slitter Rewinder operations.

Threading aids such as air showers, air trays, belt conveyors and nip roller systems are recommended to thread the tail from the unwind stand to and over the drum of the Slitter Rewinder.

## WARNING SPLICING

Splicing methods vary from plant to plant. Where splicing tables do not exist, splicing is done at the Slitter Rewinder drum area.

**EXTREME CAUTION MUST BE EXERCISED WHEN THREADING AND SPLICING TO AVOID SERIOUS PERSONAL INJURY.**

**USE EXTREME CAUTION** when threading and splicing the sheet on the Slitter Rewinder after a sheet break while a set of rolls is still on the drums. Because nips are unguarded during this process, the Slitter Rewinder must be stopped or only operated at slow speed in a thread or jog mode.

Both threading and splicing operations can be hazardous unless the operator has been given and follows the proper training.



# SAFETY INFORMATION

AN OPERATOR MUST BE WITHIN REACH OF AN EMERGENCY STOP BUTTON AT ALL TIMES WHEN THE SLITTER REWINDER IS IN MOTION DURING THREADING AND SPLICING.

OPERATORS MUST BE AWARE OF THE DANGER OF LONG HAIR, LOOSE CLOTHING OR BODY EXTREMITIES BEING PULLED INTO THE UNGUARDED NIP.

Two methods of splicing are illustrated and described here. Both methods are applicable to either threading between drums or over front drum.

2. Thread the new tail "A" between Slitter Rewinder drums using a threading device. When the full sheet is through the Slitter Rewinder, engage the slitters. Continue to run the sheet through the Slitter Rewinder until the slits are past the intended splice area. Roll tail "B" should be past the back drum nip area as this will allow you to pull roll tail "B" out. Figure 10.

## METHOD #1 SPLICING NEW TAIL UNDER ROLL TAIL

1. Clean off excess paper and make all rolls equal diameter. Figure 9

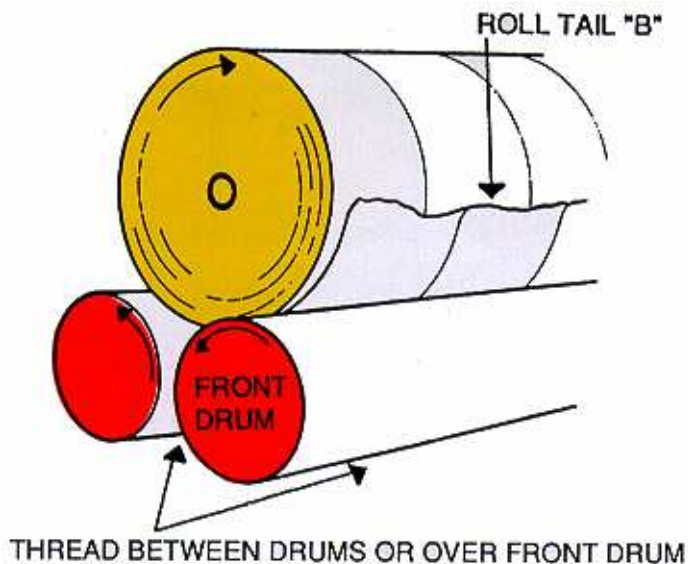

Figure 9

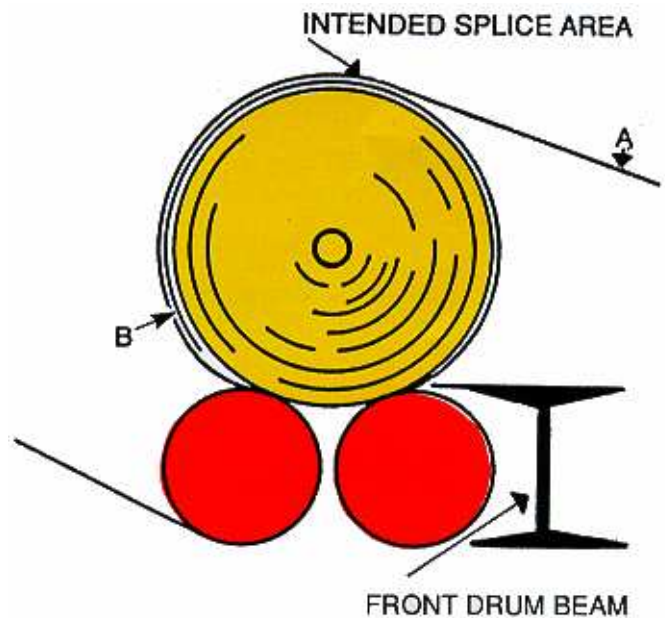

Figure 10



# SAFETY INFORMATION

## METHOD #1 Continued

3. Tear off excess new tail "A" about 12" from intended splice area. Figure 11.

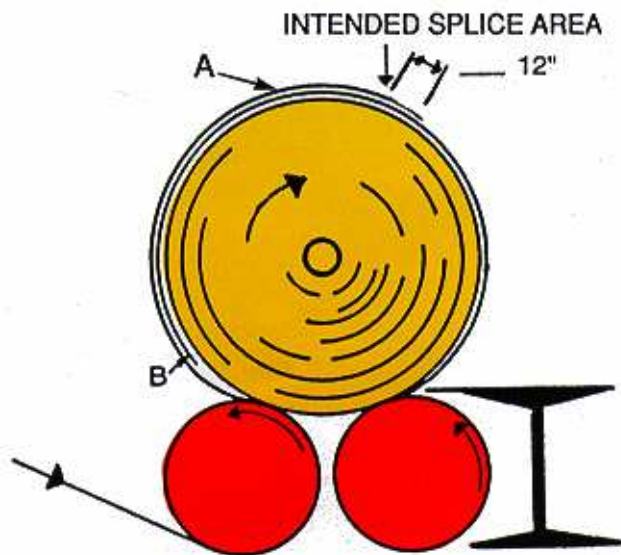

Figure 11

4. Pull roll tail "B" out and place over front drum beam. Rotate roll until intended splice area is approximately at the 3 o'clock position. Figure 12.

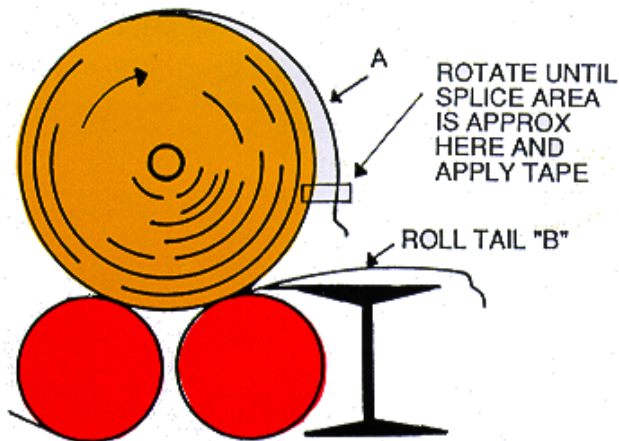

Figure 12

5. STOP SLITTER REWINDER BEFORE PROCEEDING TO STEP #6.

6. Apply splice tape in the area shown and extend tape over edges to hold new roll tail "A" in place. Tear off excess tail. Ensure excess tail extends beyond tape.

7. Take hold of old roll tail "B" and pull it up snug and flat against contact tape. Do this for each slit making sure each tail is snug and flat, then hand rub to ensure bond. Figure 13. Tear off excess roll tail "B". Figure 14.

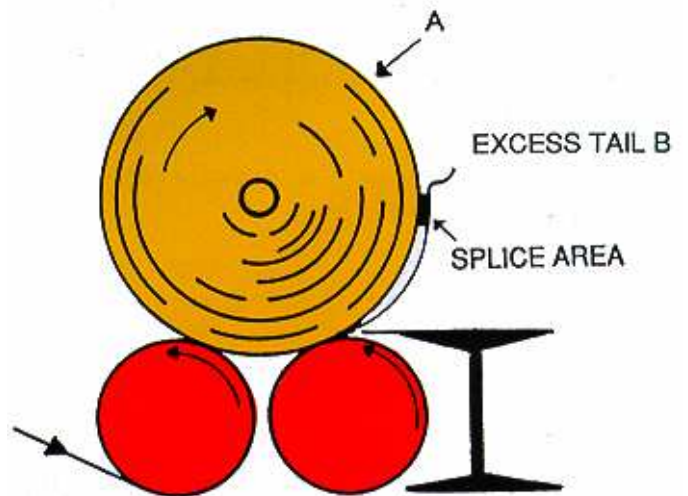

Figure 13



# SAFETY INFORMATION

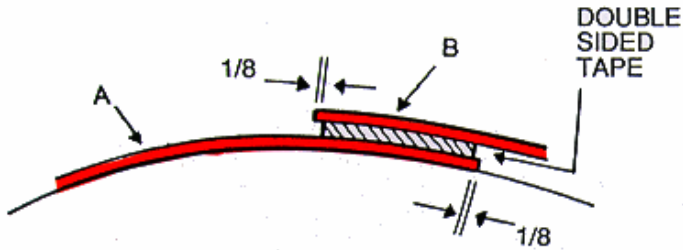

Figure 14

8. Clean off excess tape from end of set. Cut tape at each slit making sure that no excess tape or loose edges exist at the slits.
9. BEFORE continuing winding operation, ensure that all safety barriers and safety guards are in place.

4. Fold new tail "A" back over top of roll. Place splice tape over roll tail "B" extending over ends to secure in place. Figure 15. Pull out roll tail "B", cut off excess and trim to extend about 1/8" over splice tape as previously described.

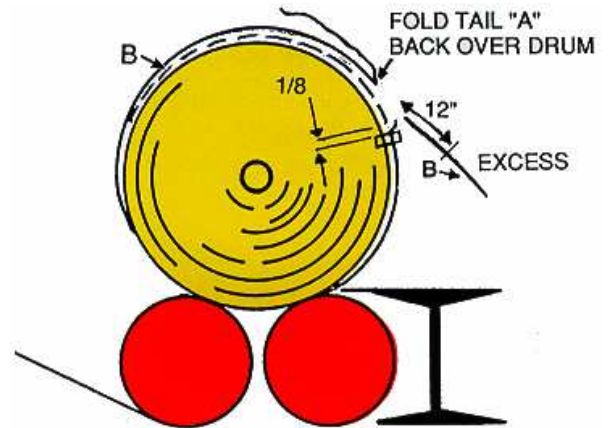

Figure 15

1. Clean off excess paper and make all rolls equal diameter. Figure 9, Page 7.
2. Thread the new tail "A" between Slitter Rewinder drums using a threading device. When the full sheet is through the Slitter Rewinder, engage the slitters. Continue to run the sheet through the Slitter Rewinder until the slits are past the intended splice area. Roll tail "B" should be past the back drum nip area as this will allow you to pull roll tail "B" out. Figure 10, Page 7.
3. Tear off excess new tail "A" about 12" from intended splice area. Figure 11, Page 8.

5. Take hold of new tail "A" and pull it down snug and flat against contact tape. Do this for each slit making sure each tail is snug and flat, then hand rub to ensure good bond. Figure 16.

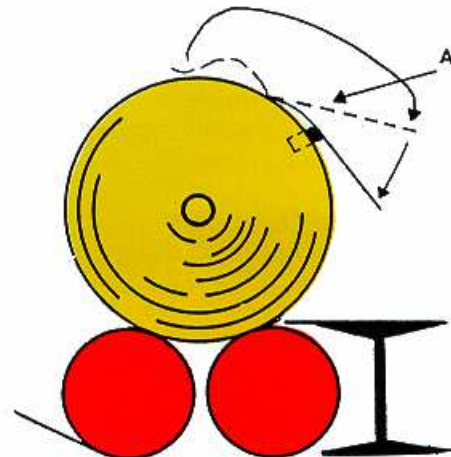

Figure 16

## METHOD #2 SPLICING NEW TAIL OVER ROLL TAIL



# SAFETY INFORMATION

## METHOD # 2 Continued

6. Tear off obvious excess and then neatly fold and tear off new tail "A". Figure 17.

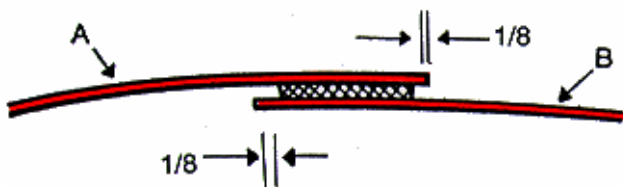

Figure 17

7. Clean off excess tape from end of set. Cut tape at each slit making sure that no excess tape or loose edges exist at the slits.
8. BEFORE continuing winding operations, ensure that all safety barriers and safety guards are in place.

## PARKING BRAKES

Davis-Standard, LLC recommends the use of Slitter Rewinder parking brakes for all new and existing two drum Rewinders.

The purpose of the Slitter Rewinder parking brakes is to prevent the Slitter Rewinder drums from rotating when the web is under a stalled tension condition while the operator is making a splice. There is also a danger that the Slitter Rewinder drums could move slightly should the web break.

OSHA requires that the drive is disengaged when the guard is raised. The operator therefore will only be able to use the jog or thread modes. Without a parking brake, the operator will be unable to maintain web tension during splicing because as soon as both the jog or thread mode are disengaged, the tension will release.

Parking brakes are also required when the unwind stand is supplied with a regenerative drive brake. This will prevent the web from being pulled back when tension is applied.

Regular inspection must be made to ensure that the Slitter Rewinder parking brakes are operational.

Slitter Rewinder parking brakes are not sized to stop the Slitter Rewinder at full speed. They are designed to be used ONLY as parking brakes during splicing and for stopping the Slitter Rewinder at the jog to thread speed.

If you have any questions concerning the application of parking brakes to your particular Black Clawson Converting Machinery Slitter Rewinder, contact Davis-Standard, LLC. Please note Davis-Standard, LLC cannot service or respond to any queries concerning any Black Clawson papermill rewinder.



# SAFETY INFORMATION

## WARNING FILLER STRIPS

The practice of using filler strips to compensate for variations in web caliper, slack splices, or misalignment of the Slitter Rewinder is hazardous and should be avoided. The use of filler strips should be viewed as a last resort measure to be used when all else fails.

Davis-Standard, LLC strongly urges plant personnel to correct the problem at the source, e.g. align backstand to Slitter Rewinder, improve splicing technique or ensure better quality control.

On shafted Slitter Rewinders, variations in web caliper can cause inter-weaving between slits. Conversion to a shaftless winding operation will help eliminate this problem by maintaining contact between the winding roll and both drums.

If a filler strip is used, then it is recommended that plants develop procedures whereby the Slitter Rewinder is stopped and the filler strip inserted using the jog speed mode.

**EXTREME CAUTION MUST BE EXERCISED WHEN INSERTING FILLER STRIPS. SERIOUS PERSONAL INJURY COULD RESULT.**

## SAFETY MATS

When a scoop lowering table is used (See Figure 8, Page 5), DSLLC recommends the use of a safety mat in the area between the Slitter Rewinder drums and the scoop lowering table so that when an operator steps on the mat, the mechanism for raising the table is disabled. Safety mats should be fixed permanently to the floor.

Safety mats must be checked frequently to ensure that they are operational. Safety mats are not an operational tool and are not to be relied upon as a substitute for safe operating procedures around Winders.

## LIGHT CURTAINS

Light curtains can be used under certain circumstances to stop the Slitter Rewinder if operators enter unsafe areas. Consult the manufacturer of your particular Slitter Rewinder BEFORE relying on light curtains as a safety device.



# SAFETY INFORMATION

## WARNING

Safety devices are no substitute for safe and proper operating procedures. Interlocks can be bypassed if the operator feels they are a hindrance to productivity. Davis-Standard, LLC only supplies interlocks that are necessary for operation.

It is the duty of the user to maintain interlocks in good repair.

**UNDER NO CIRCUMSTANCES SHOULD SUCH INTERLOCKS BE BYPASSED FOR ANY REASON.**

## WARNING

Clearly mark the operating area with yellow lines on the floor. Personnel must stay outside of these lines when the Slitter Rewinder is running.

## DANGER HIGH VOLTAGE

The Slitter rewriter is powered by electrical drives and controlled by electrical and electronic devices. These drives and controls must be properly grounded and all wiring checked periodically for loosening or damage and replaced if necessary. **LOCKOUT/TAGOUT POWER BEFORE SEVICING** any electrical device, motor, or cabinet.

In some instances, it may be necessary to troubleshoot inside a drive or control cabinet with the power on. **ONLY QUALIFIED PERSONNEL** trained to work with the power on should be allowed to bypass lockouts for troubleshooting purposes.

## WARNING CONTROL PANEL LOCATION

Make sure that nothing blocks the view of the operators at or near the machine when operating the controls.

## WARNING LOCKOUT TAGOUT

All personnel must be trained in the proper procedures for lockout/tagout. Refer to OSHA Subpart J 1910.147. Lockout and tagout devices must identify the employee applying the device.

All drives must be de-energized and locked out before performing any maintenance on a Slitter Rewinder.

Where programmable logic controllers (PLCs) are used, disable and lock out all output functions.

All controls must be locked out and all systems de-energized before performing any work on the Slitter Rewinder by any personnel.

De-energizing the Slitter Rewinder must not create a hazard. All rolls and components left in an "UP" position must be blocked or pinned up before de-energizing.

After maintenance is completed, replace all guards that were removed, ensure that no unsafe condition exists and that all personnel are clear of the Slitter Rewinder before removing the lockouts and activating the controls.

## WARNING ROTATING SHAFTS

All transmission shafts such as the main drive and auxiliary drives within the section must be guarded in accordance with OSHA's Regulation Subpart R 1910.212 & 219.



# SAFETY

# INFORMATION

## WARNING OVERHEAD CRANES

Overhead cranes are sometimes used to remove rolls. Crane operators and other personnel must be aware of all safety procedures for the safe operation of overhead cranes.

Personnel must be alerted to the hazard of the overhead crane travel. Crane operators must be aware of the possibility of workers being in the crane's path and must warn all workers to keep clear.

Slings, hooks and lifting devices must be checked regularly to ensure their good condition. Personnel must understand the proper procedures for the handling of rolls and use the proper lift points to pick up and transport equipment as recommended by the crane manufacturer.

## EMERGENCY STOPS

Slitter Rewinders must be equipped with devices that will stop the Slitter Rewinder in an emergency. OSHA states that electrically or manually operated quick power disconnecting devices, interlocked with braking action, shall be provided on all operating sides of the machine within easy reach of all employees.

TAPPI, in their Technical Information Sheet ref. TIS 0406-16, calls for emergency stopping time of 20 seconds or less.

Emergency stop devices must be tested periodically to make certain they are operational at all times.

Emergency stop devices shall be red and emergency stop pushbuttons shall have a yellow background. Stop buttons or electrical switches with letters or other markings used for emergency stopping of machinery shall be red.

Emergency stops are not safety devices and must never be used as an operational tool.

All employees must be made aware of the emergency stops in their section as part of their safety training. Reference: OSHA 1910.261, Section (k)(1) & Section (l)(2)



# SAFETY

# INFORMATION

## OPERATION

REVIEW THE FOLLOWING SAFETY RULES BEFORE OPERATING THE SLITTER REWINDER.

1. Do not remove, cover or paint over warning signs. They are installed to warn personnel of possible danger. Observe all instructions given on the signs.
2. Observe all color coding.  

ORANGE: This color indicates hazards on the machine which might cause personal injury and are to be avoided during operation. YELLOW: This color indicates caution and is used for marking physical hazards such as falling and tripping, etc. Examples would be fixed guards, cross walks and steps.
3. Footwalks, handrails, barriers, and guards must be in place before starting the machine.
4. Do not over-reach, climb, or stand on places other than properly designed and designated ladders, steps, or walkways.
5. Aisles must be clean and clear of obstructions. Wipe up spilled oil, grease and water. Good housekeeping prevents injuries.
6. Keep clothing and all parts of the body away from in-going nips, traveling belts, gears, ropes, and rotating or pivoting loading mechanisms.
7. Beware of head high obstacles in and around the machinery area. Wear proper head protection when indicated.
8. Exhaust blasts from air motors may blow dirt, scale, or other foreign materials into eyes causing eye injury. Wear proper eye protection when indicated.
9. Keep all parts of the body away from rotating drive components.
10. Any nip point on a Slitter Rewinder is a potentially hazardous area. Keep clothing and all body parts away at all times. Do not wear loose clothing that could become entangled in the roll nips.
11. Do not operate any equipment until all personnel are accounted for and are outside of safety lines.
12. Guards should be provided for all exposed head bolts on rolls. Rotating nuts or capscrews on roll heads may catch clothing or loose paper. Use caution in these areas while the machine is running. Never climb between guards and moving machinery.
13. Keep hands away from belt and chain drives. Make certain that all guards on drive components are in place.
14. When threading machinery, feet must be squarely and properly placed for adequate balance.
15. Do not use bent or damaged core shafts or reel spools with bent or damaged journals.
16. All operators must be out of the rider roll area before rider roll is lowered. Do not raise rider roll when winding shaftless until Slitter Rewinder is stopped.
17. Slitter guards must be in place before operating slitters.
18. Do not adjust slitters when in motion.
19. Slitter knives are sharp and must be handled using gloves and with caution.
20. Mirrors should be used to provide the operator with a view of the drive side area and to increase operators range of vision.



# SAFETY

# INFORMATION

## MAINTENANCE

REVIEW THE FOLLOWING SAFETY RULES BEFORE PERFORMING MAINTENANCE ON THE SLITTER REWINDER.

1. Lock out all drives and controls before working on the machinery.
2. All non-operating personnel are to be out of the area before activating drives and operating controls.
3. Inspect slings and cables for worn or weak spots before using them. Keep all personnel out from under machine components when lifting. Use lifting points specified by manufacturer. Do not allow chains or other lifting devices to hang in the aisles.
4. Do not walk under machinery, rolls, or other items being transported by overhead crane equipment.
5. Do not depend upon hydraulic or pneumatic devices to hold equipment in a raised position while performing maintenance. Pin, chain, or block in a raised position.
6. Inspect chains and clevis pins at frequent intervals for wear and damage. Block under or around units raised by chains when performing maintenance to prevent injury to personnel.
7. Tie sling securely when attempting to lift machine components. Rotation of out of balance pieces could be hazardous to personnel in the area.
8. Release pressure from oil and air lines before disassembly. Oil and air under pressure can be dangerous to personnel in the area.
9. Use protective gloves when changing out slitter knives. Lock out all power before removing.
10. Use proper stops when applying hydraulic movement equipment to bearings, heads, gears, etc. These items may travel at a high rate of speed once they have broken loose from the fit.
11. Be sure that all slings and cables are designed to lift the loads taking into consideration the angles of the hookup and the load to be lifted.
12. Do not stand astraddle of the machine line shaft or motor couplings.
13. Personal articles are not to be stored in electrical switch boxes, panels or in other potentially hazardous places.
14. Safety interlocks must be checked for proper operation as part of regular maintenance schedules.



# SAFETY INFORMATION

## UNSAFE PRACTICES

To avoid injuries, operators and other personnel should be aware of and avoid the following:

- Unguarded nip points.
- Unguarded wrap points.
- Unguarded pinch points.
- Moving parts and parts capable of moving.
- Unguarded rotating machinery.
- Unguarded moving members.
- Poor maintenance of hoist equipment.
- Improper handling of trim or web during a break.
- Inadequate barriers.
- Failure to lock out and deenergize when working on or repairing the Rewinder.
- Improper threading of machine.
- Inadequate safety signs.
- Removal of handrails and guarding.
- Improper use of footwalks, crosswalks, access steps, ladders, etc.
- Poor housekeeping, failure to keep working and traffic areas free of broke, waste material and other tripping hazards.
- Improperly protected slitter knives.
- Improper care when cleaning with chemicals.
- Improper maintenance of hydraulic hoses and fittings.
- Failure to ensure that all personnel are clear before starting the Rewinder.
- Touching the winding roll, travelling web or turning rolls.
- Adjusting slitter blades while in motion.



# SAFETY INFORMATION

## Safety Signs

### INTRODUCTION

Operators of Davis-Standard, LLC machinery, where practical and appropriate, may be protected from certain hazards by a physical barrier and may, in addition, be warned of those hazards by the placement of Safety Signs. These signs alert persons to the degree or level of the hazard, the nature of the hazard, to how the hazard can be avoided, and the consequences of involvement with the hazard.

The following examples illustrate the ANSI Z535 standard series format for product safety signs and labels. These standards must be referred to when designing safety signs and labels. Not all safety signs will have a pictorial panel.

Color-coding for the words DANGER, WARNING, CAUTION, and SAFETY INSTRUCTION is important for the identification of the hazard level.



**DANGER** – (white letters with a red background) indicates an immediate hazard that if not avoided **WILL** result in death or serious injury. This should be limited to the most extreme situations.



**WARNING** – (black letters with an orange background) indicates a potential hazard that if not avoided **COULD** result in death or serious injury.



**CAUTION** – (black Letters with a yellow background) indicates a potential hazard that if not avoided **MAY** result in minor or moderate injury.



**SAFETY INSTRUCTION** – (white letters with a green background) is used to convey multiple messages stating procedures or actions that must be followed for the safe operation of the product.



# SAFETY INFORMATION

## SELECTED OSHA REFERENCES

In the absence of specific OSHA Converting Plant Regulations, the following OSHA Regulations taken from OSHA CFR 29, Parts 1900-1910 are listed below for your reference.

- |  |               |                          |
|--|---------------|--------------------------|
| 1. Subpart J Section 1910.147 Lockout/Tagout.  | (k) (31)      | Winder Area              |
| 2. Subpart O Section 1910 Machinery & Machine Guarding. 1910.212 General Machine Guarding. | (l) (1)       | Finishing Room           |
| 3. Subpart R Section 1910.261 Pulp Paper and Board Mills. (Includes finishing room)        | (l)(2)        | Emergency Stops          |
| 4. General Requirements  | (l)(3)        | Core Collars             |
| (b) Safe Practices   | (l)(5)        | Control Panels           |
| (b) (1) Guards   | (l)(9)        | Finishing Room Rewinders |
| (b) (3) Floors and Platforms   | (l) (9) (i)   | Nip Points               |
| (c) (8) Cranes   | (l) (9) (ii)  | Surfaces                 |
| (k) Machine Room   | (l) (9) (iii) | Lifting Devices          |
| (k) (1) Emergency Stops  | (l)(10)       | Control Panels           |
| (k) (2) Drives   |               |                          |
| (k) (17) Soleplates  |               |                          |
| (k) (21) Illumination  |               |                          |
| (k) (22) Control Panels  |               |                          |
| (k) (26) In-running Nip  |               |                          |
| (k) (27) Core Collars  |               |                          |
| (k) (28) Slitter Knives  |               |                          |
| (k) (29) Winder Shaft  |               |                          |
| (k) (30) Core Shafts   |               |                          |

All machine operators, maintenance and supervisory personnel should read and understand not only the selected OSHA sections listed but all applicable OSHA codes pertaining to their job duties and functions.



# SAFETY INFORMATION

## ANSI STANDARDS

The American National Standards Institute publishes several consensus standards of interest to machinery users.

**Z535.4:** Safety Signs and Labels

**ANSI B151.5 – 2000:** Plastic Film and Sheet Winding Machinery.

**ANSI B151.2 – 1999:** Plastic Film Casting Machinery.

**ANSI B151.20 – 1999:** Plastic Sheet Production Machinery.

## NATIONAL & INTERNATIONAL STANDARDS

The International Standards Organization (ISO) and the International Electrotechnical Commission (IEC) lists many standards of interest as does the European Union whose standards are nearly identical. In addition, many countries promulgate their own standards. A source for many of these can be found at [www.global.ihs.com](http://www.global.ihs.com).

## INSTRUCTION MANUALS

It is essential that operators be thoroughly trained in turret winder safety and the procedures applicable to the process in which they are involved.

Davis-Standard, LLC provides instruction manuals with all machine orders. All operators should read and understand the information in these manuals before operating the machine.

**LACK OF PROPER TRAINING AND UNDERSTANDING CAN BE A MAJOR CAUSE OF SERIOUS PERSONAL INJURY.**

## IMPORTANT INFORMATION

**For help on how to safely operate your Davis-Standard, LLC/Black Clawson Slitter Converting Rewinder or for such assistance or help with guarding Slitter Rewinders manufactured prior to March 15, 2003 by The Black Clawson Company or Black Clawson Converting Machinery LLC, contact:**

Davis-Standard, LLC  
Black Clawson Converting Machinery  
46 North First Street  
Fulton, NY 13069, USA  
Telephone – (315) 598-7121

Please locate the serial number plate on the machine in question and write down the order number and serial number/drawing number. This will greatly expedite locating information for your specific machine.

Order No.: \_\_\_\_\_

Serial No.: \_\_\_\_\_

**Please note: Davis-Standard, LLC cannot service or respond to any queries concerning any Black Clawson Company papermill rewinder.**

